

This document provides a brief introduction and instructions to install and run the Lattice MachXO3L SMA/DSI Breakout Board Evaluation Kit on Windows 7/Vista/XP. For full documentation, schematics, demonstration programs and more go to www.latticesemi.com/breakoutboards and look for the MachXO3L SMA/DSI Breakout Board.

Two versions of the Lattice MachXO3L Breakout Board are available:

MachXO3L DSI Breakout Board (LCMXO3L-DSI-EVN)

MIPI D-PHY Input and Output connectors are installed

MachXO3L SMA Breakout Board (LCMXO3L-SMA-EVN)

SMA breakout connectors are installed

This document describes either/both boards.

1

Check Kit Contents

The following items are included in this kit:

- MachXO3L SMA/DSI Breakout Board
- USB cable
- QuickSTART Guide

2

Install USB driver & Connect the Board

1. A driver to enable the USB programming interface is included with Lattice Diamond Programmer software. Go to www.latticesemi.com/software and download/install the Programmer and Deployment Tool. Be sure to include the USB driver during installation.
2. Connect the USB cable provided between the Breakout board and your PC's USB port. LEDs will light and start to flash according to the preprogrammed design.

Note: Power can be supplied to the board via mini USB port, 12 V power supply, from a separate board through the J48 DSI input connector or any combination of the three.

3

Doing More

The source code for the demonstration program is available on the Lattice website (link above). Lattice Diamond software can be used to make modifications to this program, or develop your own designs.

*For further questions contact Lattice Technical Support at:
email: techsupport@latticesemi.com.*

Programming Selection Reference

The Lattice MachXO3L Breakout Board features two MachXO3L devices:

- **MachXO3L-2100E in 49-ball WLCSP.** This device is in a circuit optimized for MIPI D-PHY transmit and receive interfaces
- **MachXO3L-6900C in 256-ball caBGA.** This device is in a flexible IO evaluation environment.

The diagram below shows how to populate the JTAG Control Field header J50 for different programming configurations:

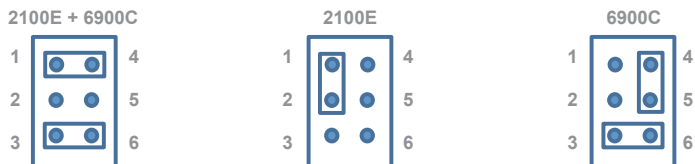

Board reference

Note: This image shows components that may not be included on the version of the board you've purchased. See the notes for more details.

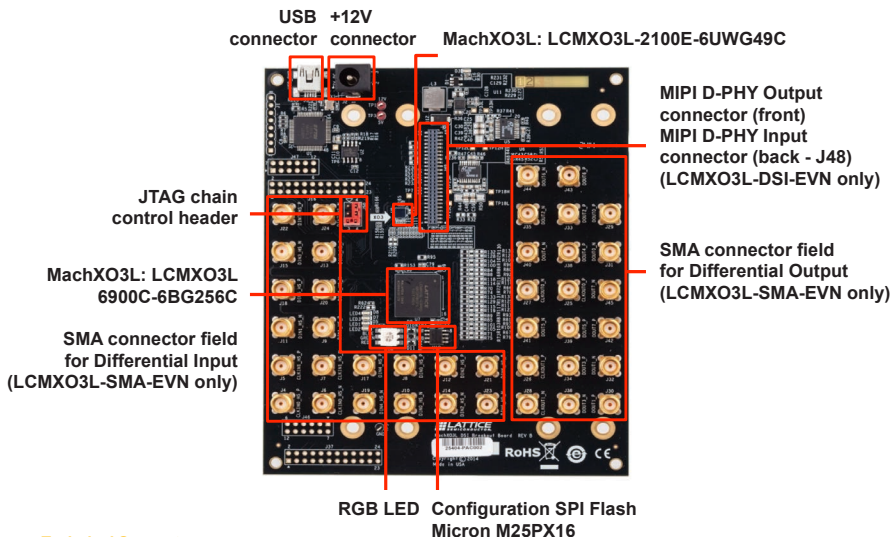

Technical Support

techsupport@latticesemi.com

Copyright © 2014 Lattice Semiconductor Corporation. Lattice Semiconductor, L (stylized) Lattice Semiconductor Corp., Lattice (design), Lattice Diamond and ECP5 are either registered trademarks or trademarks of Lattice Semiconductor Corporation in the United States and/or other countries. Other product names used in this publication are for identification purposes only and may be trademarks of their respective companies.