



Application Note 2025

CeraCharge

Rechargeable multilayer ceramic chip

- Rechargeable multilayer ceramic chip with no liquid electrolyte
- Based on a multilayer technology, similar to MLCCs, but with 1000 times the capacity of a capacitor in the same case size
- Replacement of coin cells and supercapacitors
- To increase capacity and voltage, any number of individual components can be connected in series and parallel.

Key characteristics

- **Intrinsically safe**
 - Cannot leak, burn, explode
 - RoHS compatible
- **Easy to assemble**
 - Reflow solderable
 - Embeddable
 - No need to change battery
 - Available in EIA case size
- **Robust design**
 - Wide operating temperature range
 - Suitable for vacuum applications

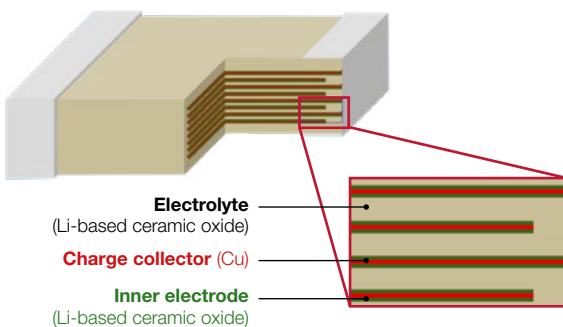

More information

www.tdk-electronics.tdk.com/en/ceracharge
or contact your local sales office

CeraCharge

Rechargeable multilayer ceramic chip

Table of contents	
1. Overview	1/3
2. Protection against humidity	4
2.1 Surface preparation	4
2.2 Dam filling	4
2.3 Appearances	4
3. Basic usage	5
3.1 Charging conditions	5
3.2 Series/parallel connection	6
3.2.1 Voltage/capacity calculation	6
3.2.2 Voltage balancing, current limitation	7
4. Application guide	8
4.1 Applications for CeraCharge	8
4.2 Use case	8
4.2.1 Low current output (e.g. RTC backup battery)	8
4.2.2 High current output (intermittently operating RF devices, e.g. IoT sensors with RF beacons)	12
4.2.3 Tips for efficient use	15
5. Charging sources	16
5.1 From system power	16
5.2 Energy harvesting	16
5.3 With other power supplies, e.g. wireless power transfer (WPT)	17
Important notes	18
Additional reference from scientific publications	19
Display of ordering codes for TDK Electronics products	19

CeraCharge

Rechargeable multilayer ceramic chip

Specification

BCT1812M101AG

Nominal voltage	V	1.5
Operating voltage	V	0 to 1.6
Maximum charge voltage	V	1.8
Nominal capacity	μAh	100
Nominal discharge current	μA	20
Operating temperature	°C	-20 to +80

1. It is recommended to operate below 1.6 V. In case cycle lifetime degradation is acceptable, it is also possible to charge up to 1.8 V.
2. At ambient condition 25 °C and relative humidity less than 60 %

Appearances

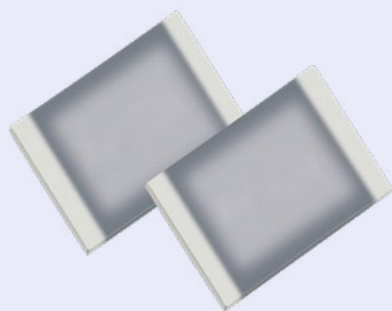

Case size	[EIA]	1812
Dimensions	[mm]	4.4 x 3.0 x 1.1

Typical characteristics

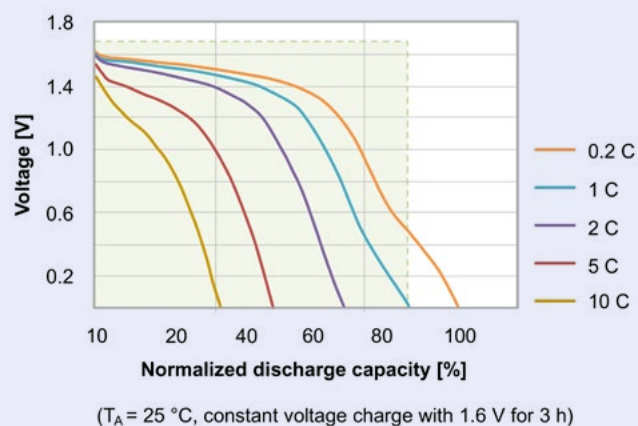

Main applications

IoT devices, real-time clocks, BLE beacons, systems for energy harvesting

- ▶ High energy density and smallest volume combined with safety and high volume manufacturing benefits of ceramic multilayer components make **CeraCharge the best option for miniaturization.**

CeraCharge

Rechargeable multilayer ceramic chip

2. Protection against humidity

CeraCharge is a humidity-sensitive device which must be operated under specified conditions (see data sheet).

In any case, adequate protection against humidity is strongly recommended for the proper functioning of the chip. The protection can be arranged for the whole or

the segment of the PCB where the CeraCharge is located, e.g. by sealing the CeraCharge-containing part in the housing of the device. Alternatively, individual CeraCharge components can be protected by onboard coating after reflow soldering. The following material and procedure can be considered as an example:

2.1 Surface preparation

The board surface, on which CeraCharge is mounted, should be free of dust, oil, grease or other dirt.

2.2 Dam filling

Recommended coating material

- Dam material: Vitralit® 1671 (Panacol-Elosol GmbH)
- Filling material: Vitralit® 1680 (Panacol-Elosol GmbH)

Thickness should be more than 0.5 mm from the CeraCharge surface.

Curing conditions

- 1. 90 sec with ca. 350 mW/cm² UV - A
- 2. Drying 30 min at 120 °C

2.3 Appearances

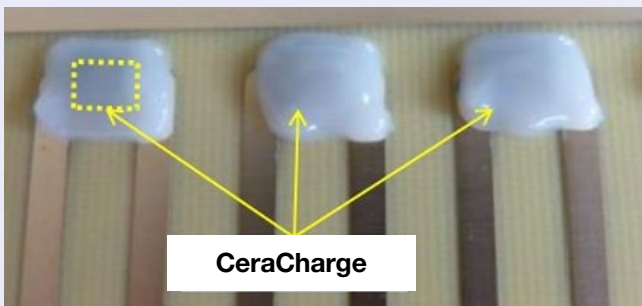

Top view

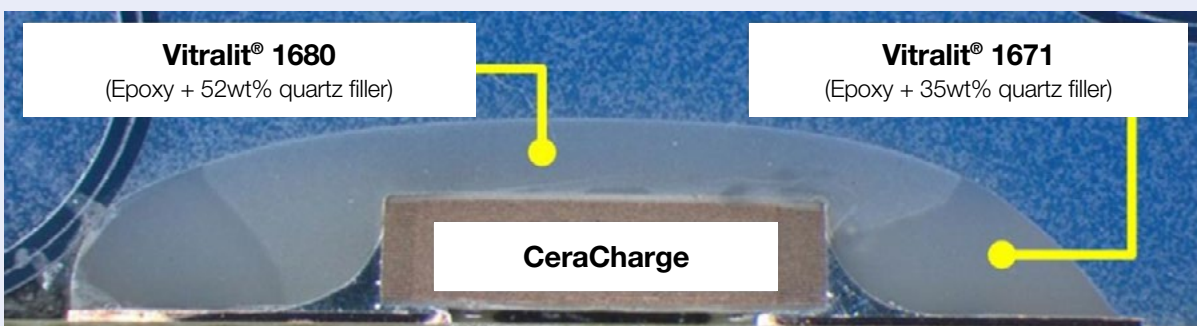

Cross section

CeraCharge

Rechargeable multilayer ceramic chip

3. Basic usage

3.1 Charging conditions

Three different charging conditions can be applied for CeraCharge.

- Constant current (CC) charging: setting current in range 10 μA up to 50 μA with end voltage of 1.6 V.
- Constant voltage (CV) charging: setting voltage to 1.6 V with limited current of less than 200 μA , end current below 10 μA .
- CC-CV charging: For constant current charge set current in range of 10 μA up to 50 μA with end voltage 1.6 V; for constant voltage charge set voltage to 1.6 V with an end current of below 10 μA .

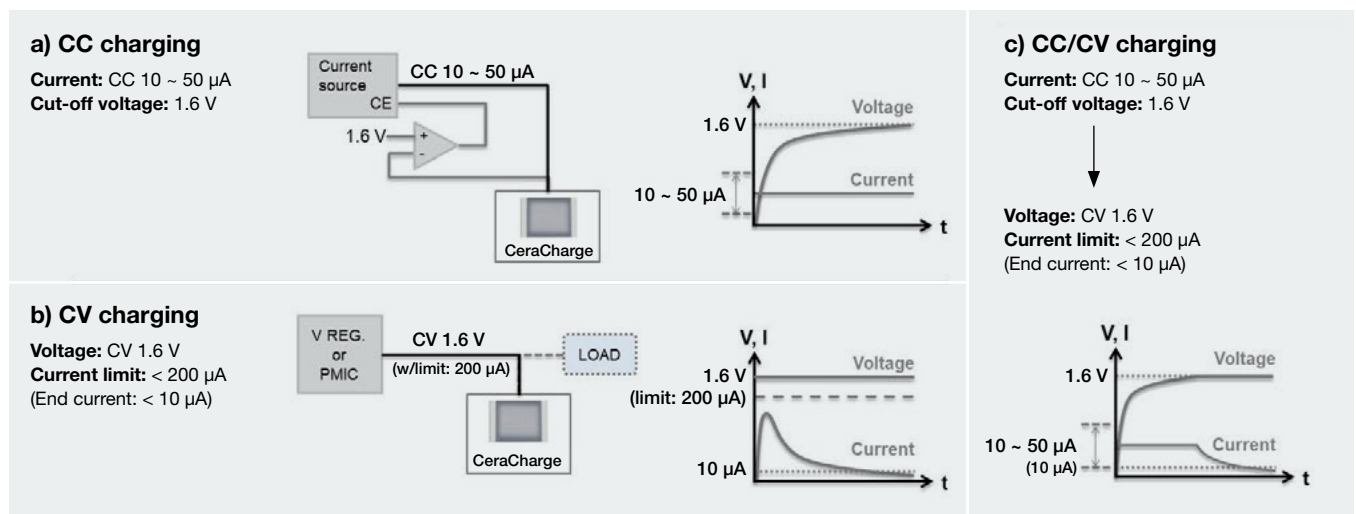

Figure 1 Charging conditions of CeraCharge

In the CC charging mode, a control circuit is needed, which has a function to stop charging by detecting the voltage when it reaches the upper control limit (V_{ucl}).

In the CV charging mode, a control circuit is needed, which has a function to stop charging by detecting the charging current lower than 10 μA . Alternatively, the charging time can serve as a rough guide to judge the end of charging. It is not a problem to continue CV charging even after the charging current falls below 10 μA .

CC-CV charging is the same method used for general-purpose LiB batteries; In this case, a control circuit is needed, which has a function to switch to CV charging after it detects that V_{ucl} has been reached.

The fully charged state is reached with CV charging at the point when the charging current drops below 10 μA . The charging time from when the capacity is at the

empty state until the charging current below 10 μA is around 3 h. (Initial charging will take approximately 5 to 6 h.)

The tendency that the charging capacity is greater than the discharging capacity (low efficiency of discharging / charging) can be observed during the first several charging cycles. This performance improves after several cycles have been repeated.

Normally the upper control limit of charging voltage is 1.6 V. The leakage current can be reduced if this is increased to 1.8 V. This method has the drawback, however, that it leads to degradation in cycle performance. For this reason, increased upper control limit of charging voltage should be used only in applications that do not require cycle performance.

CeraCharge

Rechargeable multilayer ceramic chip

3. Basic usage

3.2 Series/parallel connection

3.2.1 Voltage/capacity calculation

The following chart provides information about how the voltage and capacity in multiple connections of CeraCharge components can be calculated.

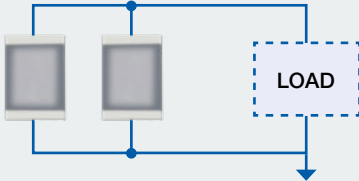
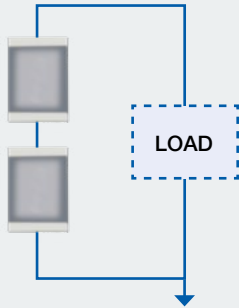
Series & parallel	1 series & 2 parallel	2 series & 1 parallel
Circuit diagram		
Discharging capacity	200 µAh	100 µAh
Output voltage	1.6 V	3.2 V

If you connect CeraCharge components in parallel, the discharging capacity becomes a multiple of the number of components connected in parallel while the discharging voltage remains unchanged.

If CeraCharge components are connected in series, the discharging voltage becomes a multiple of the number of components connected in series while the discharging capacity remains unchanged.

- **Voltage:** Multiple of number of components connected in series
- **Capacity:** Multiple of number of components connected in parallel

e.g. a CeraCharge unit with 2-series-3-parallel (2S3P) connection:

- **Voltage of upper control limit:** 3.2 V
(1.6 V * 2 series components)
- **Discharging capacity:** 300 µAh
(100 µAh * 3 parallel components)

CeraCharge

Rechargeable multilayer ceramic chip

3. Basic usage

3.2 Series/parallel connection

3.2.2 Voltage balancing, current limitation

To prevent voltage deviations of CeraCharge components connected in series it is recommended to employ some controlling circuits.

In case of a 2 in series connection, balancing resistor circuits are recommended. The resistance value of the resistors should be considered with balancing current (balancing speed) and leakage (current consumption). It should be kept in mind that this is a tradeoff relationship. (*In case of charge / discharge usage within 1.0 V to 1.6 V for each component, the CeraCharge components itself show balancing behavior. In this case, the

CeraCharge components can be used without any balancing resistor circuits. Further, constant current charging is recommended to minimize the voltage deviation.)

To align the maximum current between parallel connected components, current regulative diodes (CRD) can be used for the CeraCharge parallel line. The power supply capacity of the charging power line should be higher than the total current of all CRDs connected in parallel.

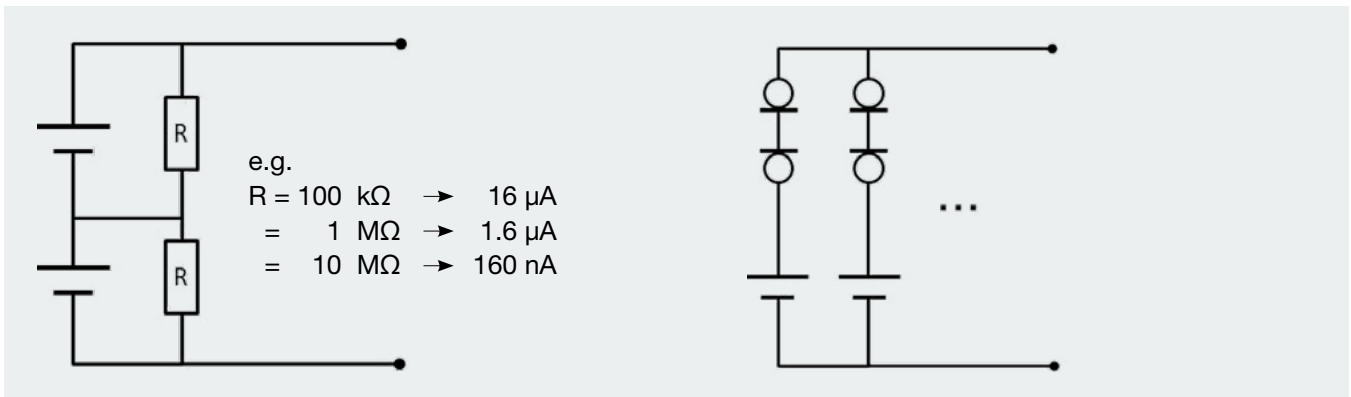

Figure 2: Balancing resistor circuit and current regulated circuit

If 3 or more CeraCharge components are connected in series, OPAMP circuits are also recommended. In this case, the leakage of resistors and the current

consumption of the OPAMP must be taken into consideration.

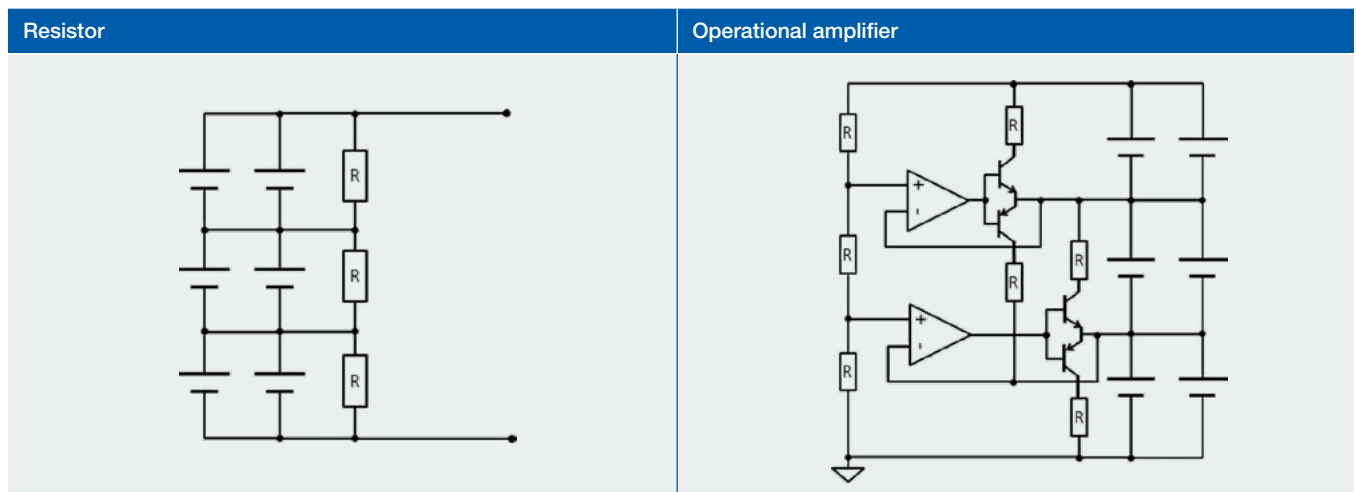

Figure 3: Balancing resistor (passive) circuit and Operational amplifier (active) circuit

CeraCharge

Rechargeable multilayer ceramic chip

4. Application guide

4.1 Applications for CeraCharge

Power backup	IoT (energy harvesting)	Sub	Wearable, health care
e.g. Real time clocks	e.g. Beacons environment sensor	e.g. Battery life extender	e.g. Thermometer hearing aid

4.2 Use case

4.2.1 Low current output (e.g. RTC backup battery)

CeraCharge is suitable for applications that require discharging over a long time with a low current.

Its use as a backup battery for Real Time Clock (RTC) ICs, in which CeraCharge discharges a very small current continuously, is one of the most suitable applications. CeraCharge, which delivers 100 μ Ah in a miniature 1812 case, can reduce the mounting area on the PCB surface by replacing the larger commonly used coin-cell batteries.

Although the leakage current of a backup battery also affects the operating time of RTC-IC, CeraCharge

reduces its leakage current by extending the charging time. For example, after charging for 100 h the leakage current will decrease to 0.1 μ A, much lower than that experienced when charging is only for a period of several hours.

(Normally the upper control limit of charging voltage is 1.6 V. The leakage current can be reduced if this is increased to 1.8 V. This method has the drawback, however, that it leads to degradation in cycle performance. For this reason, it should be used only in applications in which cycle performance is not highly required.)

Connection image

Connecting variations are generally divided into 2 types as shown in Figure 4.

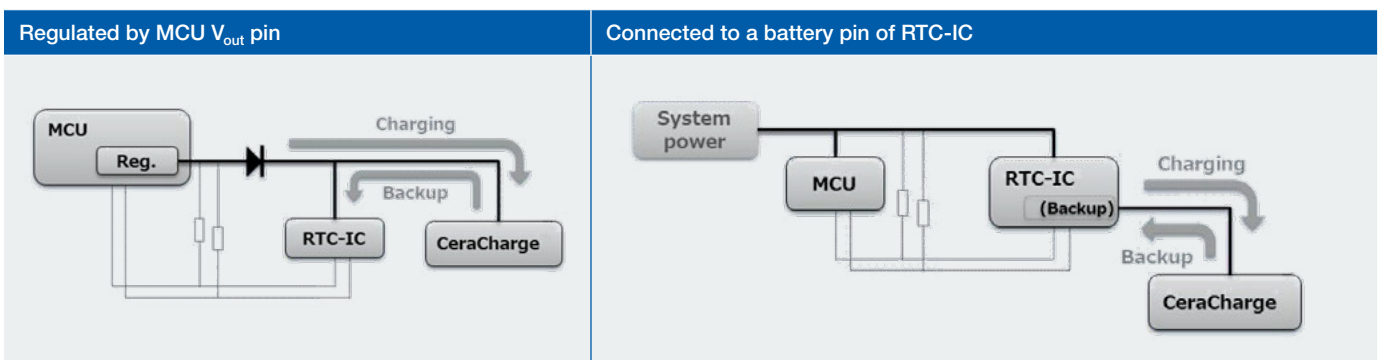

Figure 4: Block diagram of CeraCharge connection for RTC backup circuit

CeraCharge

Rechargeable multilayer ceramic chip

4. Application guide

4.2 Use case

4.2.1 Low current output (e.g. RTC backup battery)

Some RTC-IC products (e.g. Micro Crystal RV-3032-C7) have a battery backup mode and are equipped with a pin for connecting a backup battery. CeraCharge can be connected to this pin.

A CeraCharge backup circuit can also be implemented in RTC-ICs that do not have a backup mode. In this case, CeraCharge should be connected to the VDD pin in parallel with the main power source. It is also recommended to insert a diode before the parallel point of the RTC and CeraCharge on the system power line in order to prevent a current backflow from the CeraCharge

to the system power line when the system power is shut down.

As mentioned above, when the CeraCharge is connected to RTC circuits as a backup battery with charging and discharging, CeraCharge must be connected to the power line from the MCU (system power) or the backup pin of the RTC-IC. The number of CeraCharge connected in series (= charging voltage) is determined by the supply voltage from the MCU (system power) or the backup pin of the RTC-IC.

Operating time calculation

Figure 5 shows an example of the measurement results of an RTC backup circuit with CeraCharge.

TC-IC: R2051S01 (RICOH Electronic Devices Co., Ltd.)

- Current consumption: 0.4 μA
- Minimum time keeping voltage: 0.75 V typ.

CeraCharge:

- Charging: CV 1.8 V, 100 h \rightarrow connected to the backup pin of the RTC-IC as 1 cell

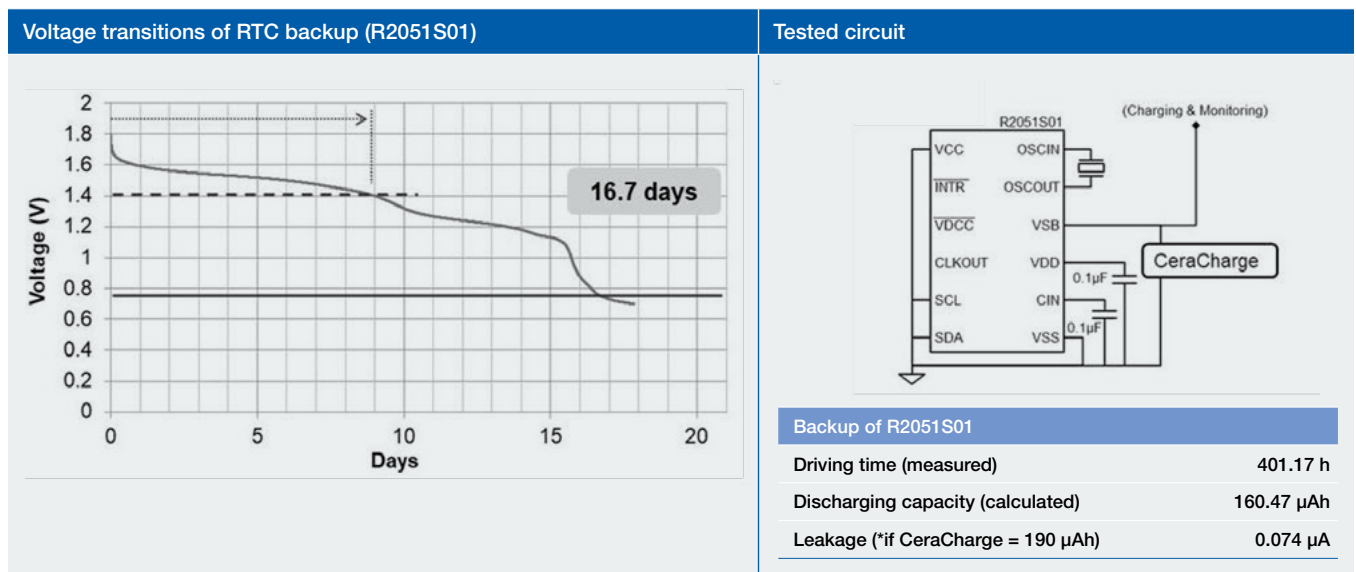

Figure 5: RTC (R2051S01) backup circuit test result

CeraCharge

Rechargeable multilayer ceramic chip

4. Application guide

4.2 Use case

4.2.1 Low current output (e.g. RTC backup battery)

In this case, CeraCharge was able to back up the RTC-IC for 16.7 days (400 h) with a backup voltage of 1.8 V to 0.75 V. Based on the current consumption of this RTC-IC, CeraCharge thus supplied 160 μAh to the RTC-IC until it reached its minimum time keeping voltage. Since the full discharging capacity of CeraCharge is roughly 190 μAh when it is charged to 1.8 V, the calculated leakage current during this operating is 0.074 μA .

The operating time calculation takes the current consumption of the RTC-IC and the leakage current

of CeraCharge into consideration, as shown on the previous page. Moreover, in order to use CeraCharge capacity more efficiently, the operating voltage range of the RTC-IC must also be considered. The minimum time keeping voltage of this RTC-IC (0.75 V) is shown in the graph as a solid line. If the minimum time keeping voltage is higher, for example 1.4 V as shown by the dashed line, CeraCharge will not be able to supply 50 % of the capacity to the RTC-IC. In this case, the capacity of CeraCharge would only be sufficient to drive the RTC-IC for around 200 h.

Figure 6 is a measurement result with another IC of which both the current consumption and minimum time keeping voltage are lower than the R2051S01.

The actual driving time cannot be calculated based on current consumption and capacity alone. The leakage current is also needed for this calculation.

RTC-IC: R2221T (RICOH Electronic Devices Co., Ltd.)

- Current consumption: 0.18 μA
- Minimum time keeping voltage: 0.6 V typ.

CeraCharge:

- Charging: CV 1.8 V, 100 h \rightarrow connected to the backup pin of the RTC-IC as 1 cell

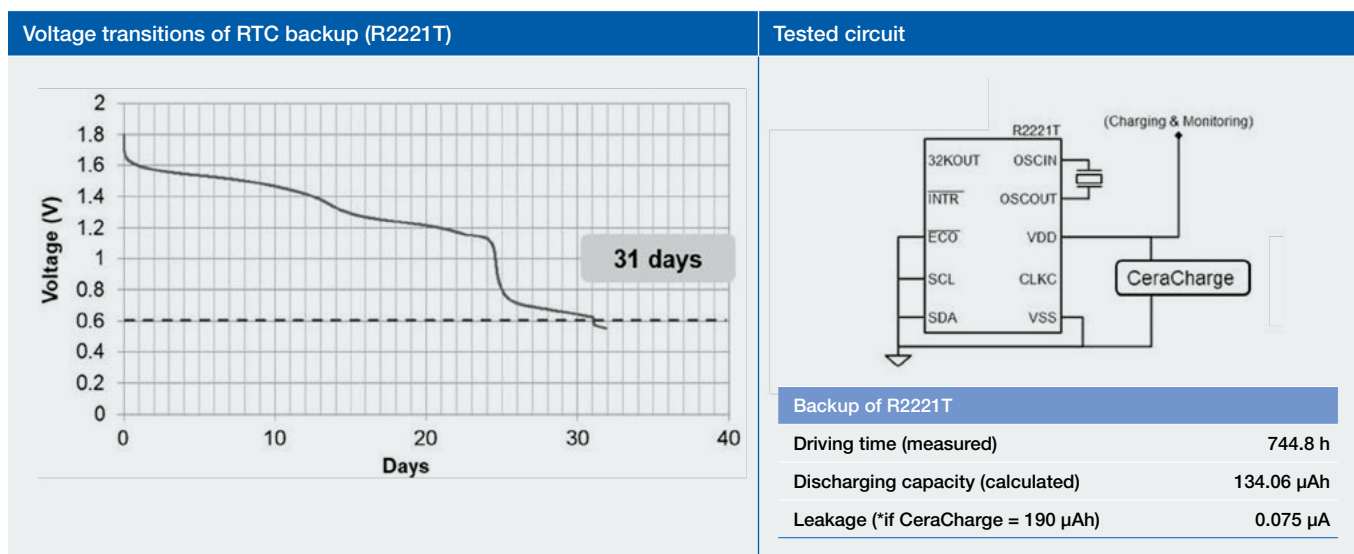

Figure 6: RTC (R2221T) backup circuit test result

CeraCharge

Rechargeable multilayer ceramic chip

4. Application guide

4.2 Use case

4.2.1 Low current output (e.g. RTC backup battery)

Simplified chart of operating time calculation

The operating time with CeraCharge can be roughly estimated from following graphs.

Figure 7a is a simplified chart with charging of 1.6 V for 100 h. Figure 7b is another one with 1.8 V charging and including the measured data for R2051S01 and R2221T.

(*This is an ideal calculation based on measurements with an initial cycle of the CeraCharge component. The operating time depends on actual conditions and environment.)

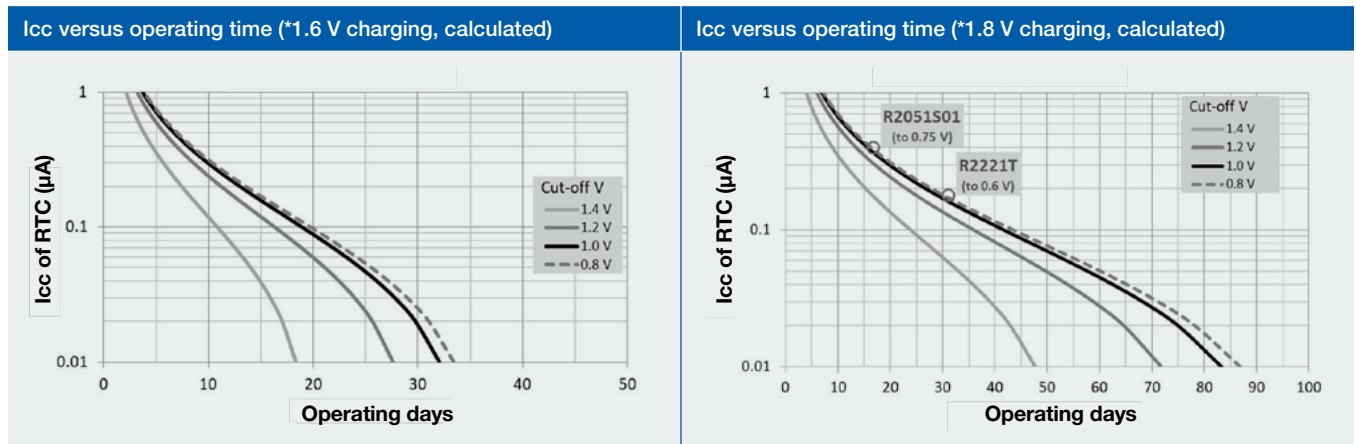

Figure 7a and 7b: Simplified chart of current consumption vs. operating time with charging at 1.6 V (7a) and 1.8 V (7b) for 100 h

Cycle degradation of 1.8 V charging

Figure 8 shows the cycle comparison between charging at 1.8 V and 1.6 V charge. (This data is just an example.)

The actual capacity depends on its conditions, environment, and discharging depth.)

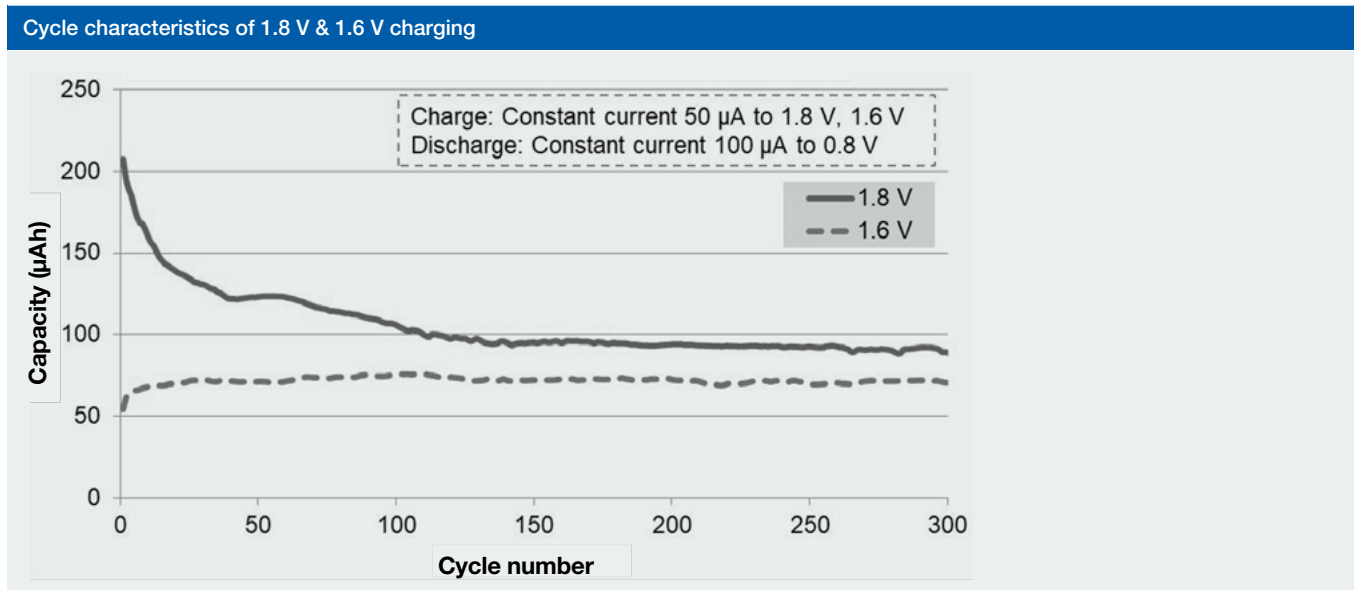

Figure 8: Cycle comparison for charging at 1.8 V and 1.6 V

CeraCharge

Rechargeable multilayer ceramic chip

4. Application guide

4.2 Use case

4.2.2 High current output (intermittently operating RF devices, e.g. IoT sensors with RF beacons)

Because of its high inner resistance CeraCharge is not suitable for a continuous discharge current in the mA range (as required to drive LEDs, bright graphic displays, or high quality speakers, for example). In applications that require mA currents, the discharging voltage of CeraCharge could drop due to the inner resistance and then not be able to supply enough power to the load.

There are, however, some applications that require mA current discharging and can be supported by

CeraCharge. Figure 9 shows the potential of CeraCharge in applications with intermittent driving systems such as RF beacons. These applications can require a pulse current of several mA with large intervals in the second to minute range.

As the typical pulse power in this table shows, if the interval between each square pulse is 30 s, CeraCharge can discharge a 3 mA current square pulse for a maximum time of 1 s.

Typical pulse power ($T_A = 25\text{ }^\circ\text{C}$)

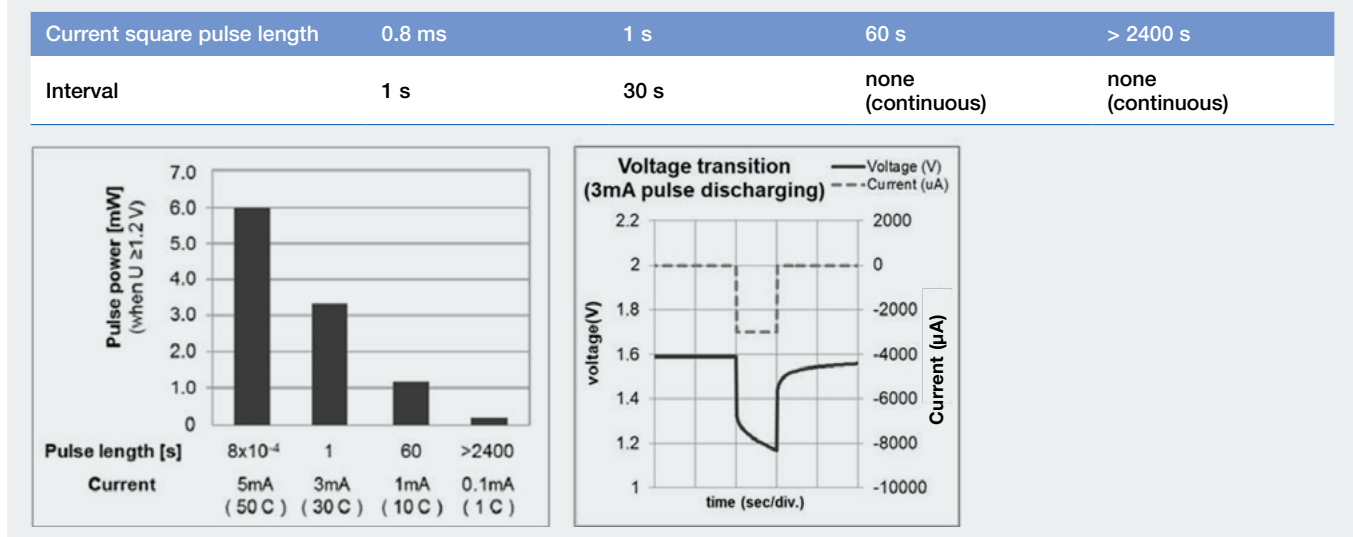

Figure 9: Typical pulse power and pulse discharging test result of CeraCharge

Block diagram

In the case of transmitting devices that have an intermittent operating mode with a pulse current of several mA, CeraCharge can prevent a voltage drop in the power line with low impedance capacitors connected

in parallel. The capacitors supply the power needed for a single transmission, and CeraCharge then charges capacitors for subsequent transmissions.

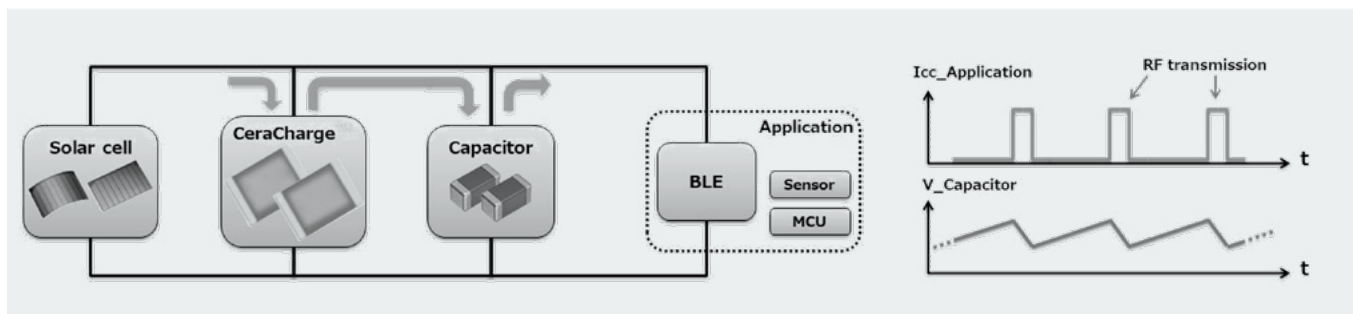

Figure 10: CeraCharge connection & operating image for intermittently operating RF devices

CeraCharge

Rechargeable multilayer ceramic chip

4. Application guide

4.2 Use case

4.2.2 High current output (intermittently operating RF devices, e.g. IoT sensors with RF beacons)

Energy calculation

In order to calculate how long applications can be driven with CeraCharge, one must convert their power consumption to the capacitance of capacitors and the capacity of batteries.

(*This is an ideal value in a case if we can convert all energy of battery capacity to an electric energy with some voltage value.)

$$100 \mu\text{Ah} = 360000 \mu\text{A} \cdot \text{s} = 360000 \mu\text{C} = 240000 \mu\text{F} \cdot 1.5 \text{ V}$$

As a result, 100 μAh of CeraCharge capacity is equivalent to 240 mF of capacitance with a voltage drop of 1.5 V. CeraCharge with its capacity of 100 μAh in an 1812 case size can serve as a new kind of power supply for IoT edge devices and thus contribute to the miniaturization of beacon devices and environment sensing devices.

value and transmitting intervals are used to calculate the average power consumption.

Energy consumption of an application

- Voltage: 3.0 V
- Current: 10 mA
- Pulse width: 10 ms (as 1 pulse for RF transmitting)
- Energy (μJ) = 3.0 V * 10 mA * 10 ms = 300 μJ

The transmitting power of RF devices can be calculated as shown in the following example. Subsequently, this

How many pulses can be transmitted by CeraCharge?

Figure 11 provides a rough calculation of the number of transmitted pulses with two pulses configuration

patterns. Figure 12 shows an operating time calculation with pulse configuration 2 in Figure 11.

Pulse configuration	Note	Pulse number with 100 μAh
1 3.0 V * 10 mA * 10 ms (= 300 μJ)	(As shown above)	> 3500 pulses
2 1.8 ~ 3.6 V * 5 mA * 4 ms (= 36 ~ 72 μJ)	(Example of BLE Beacon devices)	> 18000 pulses

Figure 11: Rough calculation of transmitting pulse numbers in each pulse configurations

Interval time (pulse /)	Operating time
1 s	≈ 5 h
1 min	≈ 12 days
5 min	≈ 62 days

Figure 12: Operating time calculation in each interval with "pulse configuration 2" in Figure 12.

If the power of 1 pulse is 300 μJ as shown above, the converted capacity is 0.028 μAh at 3.0 V. The CeraCharge components connected 2 in series (and 1 parallel) can support more than 3500 pulses in the calculation with 100 μAh capacity.

In this case, the actual capacity that the CeraCharge components can support is only for discharging pulse above 3.0 V, since its load requires a pulse current with 3.0 V input.

CeraCharge

Rechargeable multilayer ceramic chip

4. Application guide

4.2 Use case

4.2.3 Tips for efficient use

Capacity calculation of operating time

As shown above in the section about RTC backup circuits, this voltage range must also be taken into consideration when calculating the operating time of applications. CeraCharge's nominal capacity of 100 μ Ah is based on a 0.2 C discharging rate to 0 V. If the low limit voltage of an application is 1.4 V,

however, the actual discharging capacity value that can be used in this application is in the range of 1.6 V to 1.4 V.

It is recommended that charging and discharging voltage remain within the "efficient range" given in the diagram below.

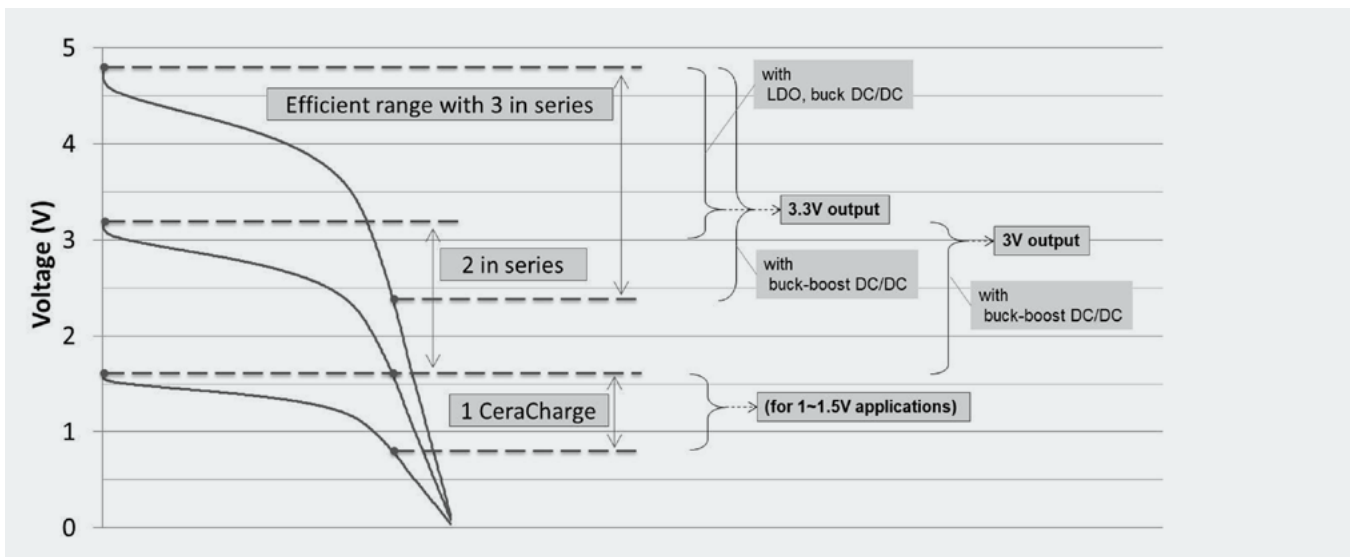

Figure 14: Efficient voltage range of CeraCharge and output

Example circuit of energy harvesting RF device

Figure 15 shows the block diagram of a 3 V output circuit with a DC/DC buck-boost and two CeraCharge components connected in series.

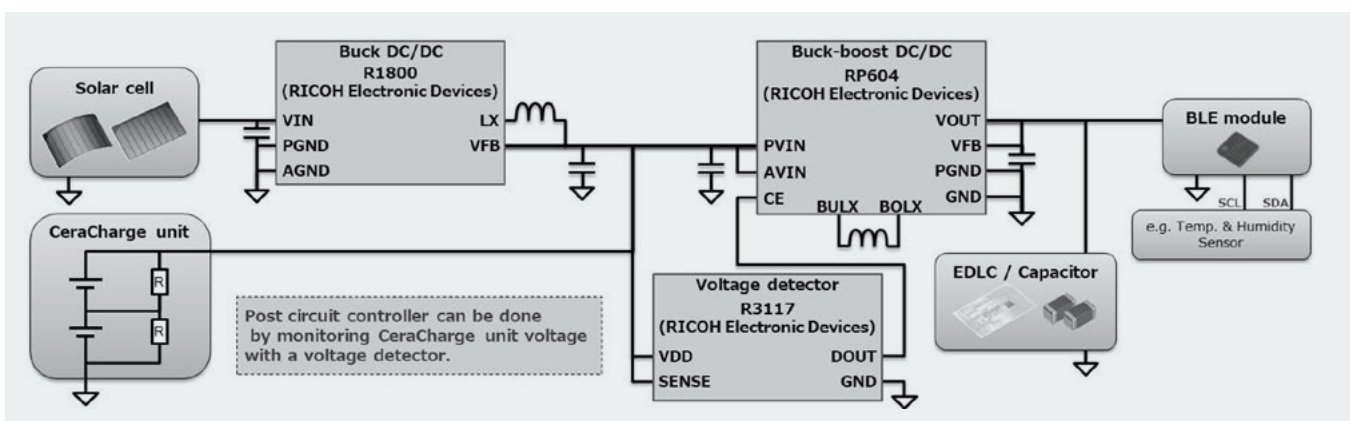

Figure 15: Example circuit of an energy harvesting RF device

CeraCharge

Rechargeable multilayer ceramic chip

5. Charging sources

5.1 From system power

In applications such as RTC-ICs, which have a power supply for normal operation, CeraCharge can be connected in parallel with the power supply. In this configuration, CeraCharge will start discharging to the

load when the power supply is shut off. Therefore, it is necessary to determine the number of CeraCharge components connected in series considering the voltage range of the power supply.

Regulated by MCU V_{out} pin

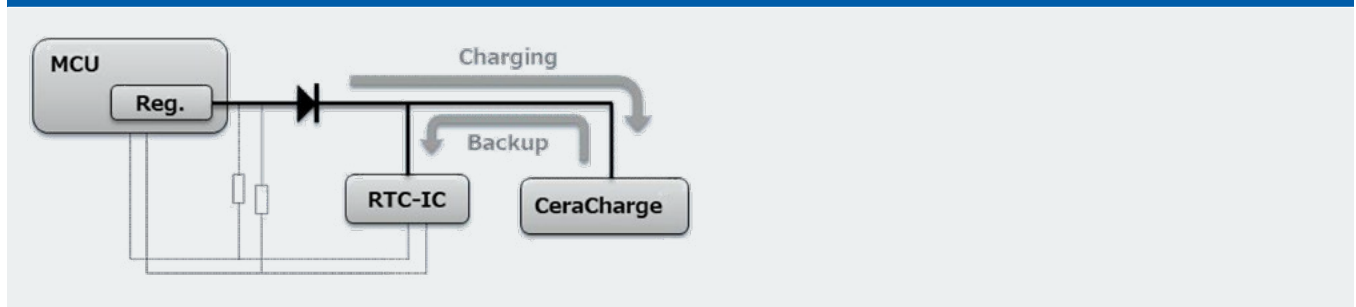

Figure 16: RTC backup circuit connected in parallel with system power line

5.2 Energy harvesting

If power is supplied in an environment without a stable power supply by a solar cell or by energy harvesting devices such as piezo or thermoelectric elements, it

is recommended to stabilize the charging power with voltage regulators or power management ICs.

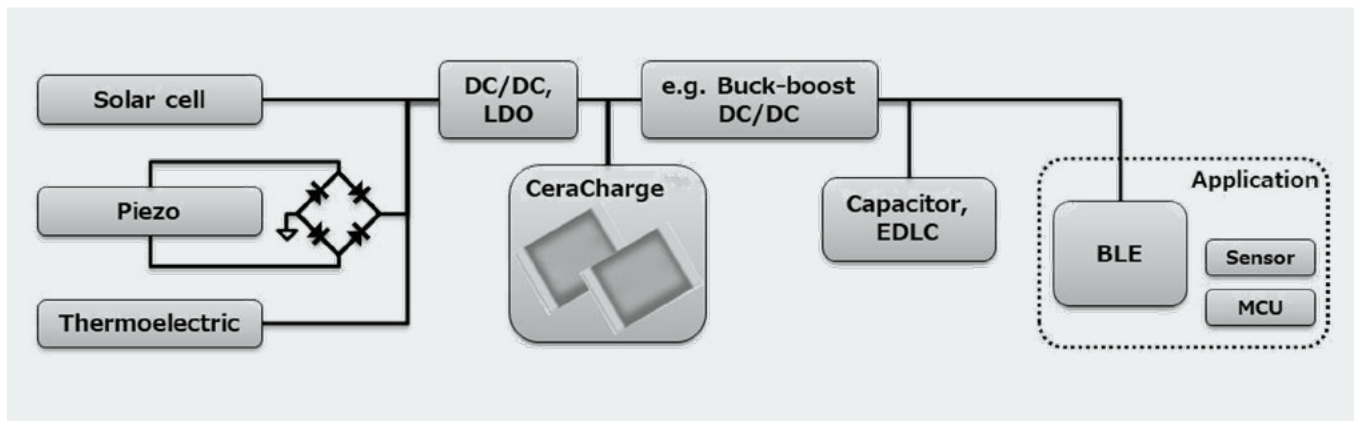

Figure 17: RF energy harvesting device with PMIC (power management IC) control circuit

CeraCharge

Rechargeable multilayer ceramic chip

5. Charging sources

5.3 With other power supplies, e.g. wireless power transfer (WPT)

CeraCharge can be charged from a wireless power supply coil based on a low-power wireless charging standard such as Qi or NFC.

This power must be rectified to DC by a rectifier circuit (e.g. with diodes and capacitors).

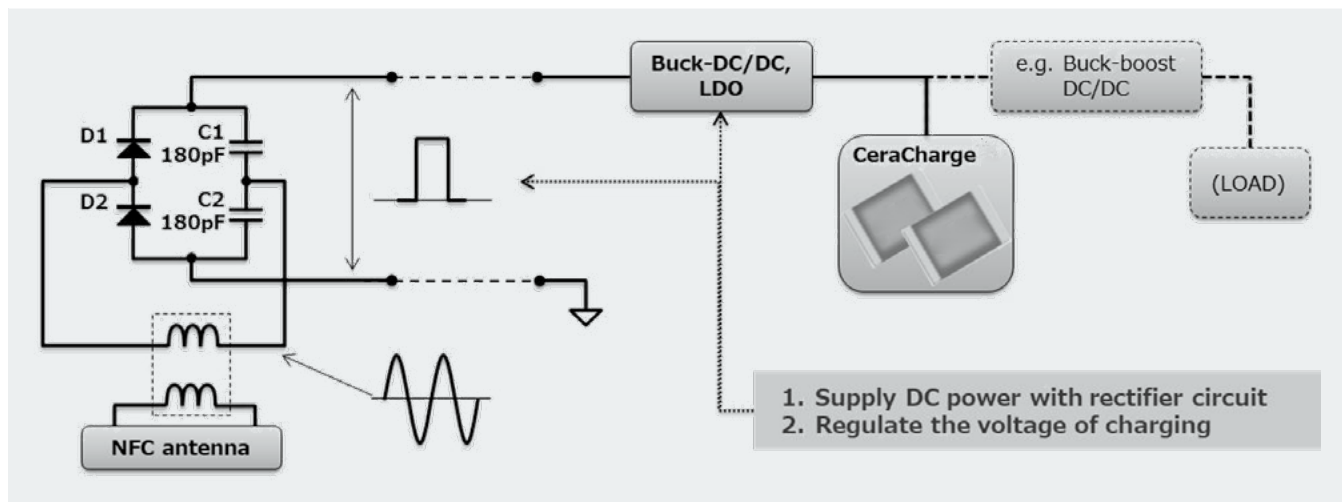

Figure 18: Rectifier circuit for wireless charging from NFC power

The above list of applications for CeraCharge does not claim to be complete, but merely reflects the experience of TDK Electronics AG.

Important notes

The following applies to all products named in this publication:

1. Some parts of this publication contain **statements about the suitability of our products for certain areas of application**. These statements are based on our knowledge of typical requirements that are often placed on our products in the areas of application concerned. We nevertheless expressly point out **that such statements cannot be regarded as binding statements about the suitability of our products for a particular customer application**. As a rule we are either unfamiliar with individual customer applications or less familiar with them than the customers themselves. For these reasons, it is always ultimately incumbent on the customer to check and decide whether a product with the properties described in the product specification is suitable for use in a particular customer application.
2. We also point out that **in individual cases, a malfunction of electronic components or failure before the end of their usual service life cannot be completely ruled out in the current state of the art, even if they are operated as specified**. In customer applications requiring a very high level of operational safety and especially in customer applications in which the malfunction or failure of an electronic component could endanger human life or health (e.g. in accident prevention or life-saving systems), it must therefore be ensured by means of suitable design of the customer application or other action taken by the customer (e.g. installation of protective circuitry or redundancy) that no injury or damage is sustained by third parties in the event of malfunction or failure of an electronic component.
3. **The warnings, cautions and product-specific notes must be observed.**
4. In order to satisfy certain technical requirements, **some of the products described in this publication may contain substances subject to restrictions in certain jurisdictions (e.g. because they are classed as hazardous)**. Useful information on this will be found in our Material Data Sheets on the Internet (www.tdk-electronics.tdk.com/material). Should you have any more detailed questions, please contact our sales offices.
5. We constantly strive to improve our products. Consequently, **the products described in this publication may change from time to time**. The same is true of the corresponding product specifications. Please check therefore to what extent product descriptions and specifications contained in this publication are still applicable before or when you place an order.

We also **reserve the right to discontinue production and delivery of products**. Consequently, we cannot guarantee that all products named in this publication will always be available.

The aforementioned does not apply in the case of individual agreements deviating from the foregoing for customer-specific products.
6. Unless otherwise agreed in individual contracts, **all orders are subject to our General Terms and Conditions of Supply**.
7. **Our manufacturing sites serving the automotive business apply the IATF 16949 standard**. The IATF certifications confirm our compliance with requirements regarding the quality management system in the automotive industry. Referring to customer requirements and customer specific requirements ("CSR") TDK always has and will continue to have the policy of respecting individual agreements. Even if IATF 16949 may appear to support the acceptance of unilateral requirements, we hereby like to emphasize that **only requirements mutually agreed upon can and will be implemented in our Quality Management System**. For clarification purposes we like to point out that obligations from IATF 16949 shall only become legally binding if individually agreed upon.
8. The trade names EPCOS, CarXield, CeraCharge, CeraDiode, CeraLink, CeraPad, CeraPlas, CSMP, CTVS, DeltaCap, DigiSiMic, FilterCap, FormFit, InsuGate, LeaXield, MediPlas, MiniBlue, MiniCell, MKD, MKK, ModCap, MotorCap, PCC, PhaseCap, PhaseCube, PhaseMod, PhiCap, PiezoBrush, PlasmaBrush, PowerHap, PQSine, PQvar, SIFERRIT, SIFI, SIKOREL, SilverCap, SIMDAD, SiMic, SIMID, SineFormer, SIOV, SurfIND, ThermoFuse, WindCap, XieldCap are **trademarks registered or pending** in Europe and in other countries. Further information will be found on the Internet at www.tdk-electronics.tdk.com/trademarks.

Release 2024-02

Additional reference from scientific publications:

[1] Lauer, F., Schöffel, M., Rheinländer, C.C., Wehn, N. (2023). Exploration of Thermoelectric Energy Harvesting for Secure, TLS-Based Industrial IoT Nodes. In: Tekinerdogan, B., Wang, Y., Zhang, L.J. (eds) Internet of Things – ICIOT 2022. ICIOT 2022. Lecture Notes in Computer Science, vol 13735. Springer, Cham. https://doi.org/10.1007/978-3-031-23582-5_7

Display of ordering codes for TDK Electronics products

The ordering code for one and the same product can be represented differently in data sheets, data books, other publications, on the company website, or in order-related documents such as shipping notes, order confirmations and product labels. **The varying representations of the ordering codes are due to different processes employed and do not affect the specifications of the respective products.** Detailed information can be found on the Internet under www.tdk-electronics.tdk.com/orderingcodes.