



Application Note

Power Management and Customer Sensing with Zilog's ZMOTION™ Detection Module

AN030103-1010



Abstract

This Application Note describes how to manage power on electrical appliances with Zilog's ZMOTION™ Detection Module featuring advanced passive infrared technology. For this application note, we will use a Digital Picture Frame (DPF) to illustrate the power savings that can be achieved with this technology. This same concept can be used to save power in many other applications such as vending machines, kiosks and information display systems.

A typical household will have its Digital Picture Frame continuously run even without anyone viewing the pictures. This setup is a waste of energy and decreases the LCD lifespan. However, incorporating the Digital Picture Frame with a ZMOTION™ Detection Module a household can save on energy as the DPF will turn ON only when it senses somebody in front of the display.

ZMOTION™ technology relies on warm body motion to trigger a set of desired reaction. This technology may be used to implement power management in lighting fixtures, electrical appliances or vending machines.

ZMOTION™ Detection Module Overview

Zilog's ZMOTION™ Detection Module is a complete and fully functional motion detection solution, ideal for lighting control and other occupancy and proximity detection applications. It is a board level module that combines the unique features of Zilog's Z8FS040 Motion Detection Microcontroller with a Pyroelectric Sensor and a low profile Fresnel lens.

Parameters for sensitivity and output timing are provided through a simple hardware interface, or more advanced settings and status are available through a serial interface. In either mode; sensitivity and delay time can be controlled to match the application requirements.

The ZMOTION™ Detection Module is a great way to reduce design effort and eliminate development risk for any device that needs motion detection capability. It is a great choice for lighting controls, access control, display systems and general purpose proximity sensing. It is also an easy way to add energy management capability to various applications such as vending machines and appliances.

Features

The main features of the ZMOTION™ Detection Module include:

- Complete, fully functional motion detection SBC including Fresnel lens
- Pre-Programmed with motion detection software
- Small form factor — 25.5 mm x 16.7 mm
- Wide 5 m x 5 m, 60 degree detection Pattern
- Sensitivity control via simple hardware configuration
- Advanced serial (UART) based configuration and interface
- SLEEP mode for low-power applications
- No temperature compensation required
- Input to support CDS photocell input for ambient light detection
- Minimal components ensure highest possible Mean Time Between Failures(MTBF)
- Application code can also be modified to support custom solutions
- Complete development system available

Discussion

This application note uses a Digital Picture Frame and the ZMOTION™ Detection Module in Hardware Interface Mode to illustrate how power management can be incorporated into simple household appliances. This section describes the hardware connections of the ZMOTION™ Detection Module and DPF, while the flowchart describes the Customer Sensing Application.

Hardware Architecture

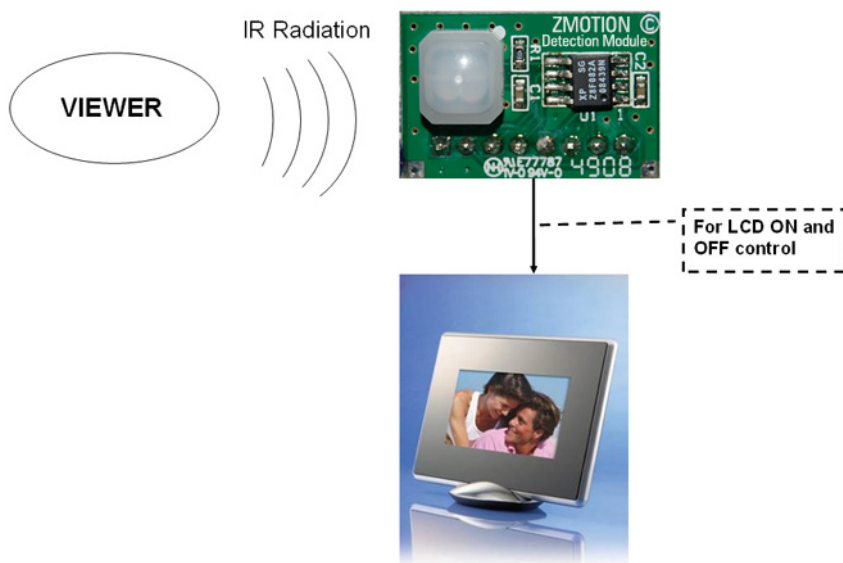

Figure 1: Hardware Setup

shows the application flow from the ZMOTION™ Detection Module to the DPF. The ZMOTION™ Detection Module continuously monitors for motion within its detection area. When motion is detected, this will turn ON the LCD and displays the pictures for the viewer. The module will turn OFF the LCD when there is no motion for a predefined period of time.

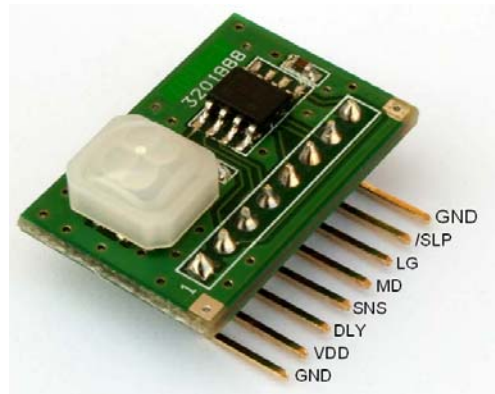

Figure 2: ZMOTION™ Detection Module Pin Diagram

Table 1: ZMOTION™ Detection Module Pin Description

Pin No.	Signal Name	Hardware Interface Mode	Serial Interface Mode	Description
1	GND	Ground	Ground	-
2	VDD	Supply Voltage	Supply Voltage	-
3	RXD/DLY	DLY-Delay (analog input)	RXD Receive Data (digital input)	-
4	TXD/SNS	SNS Sensitivity (analog input)	TXD Transmit Data (digital input)	Mode select during Reset
5	/MD/RST	Motion Detect (digital output)	Configurable: /RST Reset (digital input) /MD Motion Detect (digital input)	Default is /RST (Reset) in Serial Interface Mode
6	LG	Light Gate (analog input)	Light Gate (analog input)	If unused, connect to V _{dd}
7	/SLP/DBG	/SLP Sleep (digital input)	/SLP Sleep (digital input)	DBG is used for programming and debug
8	GND	Ground	Ground	-

Note: Hardware Interface Mode is used in this application note

Figure 2 and Table 1 illustrate and describe the pin diagram of ZMOTION™ Detection Module. The

module is capable of operating in a Serial Interface Mode and a Hardware Interface Mode. For this application note, the module will be used in HARDWARE INTERFACE MODE.

Circuit Description

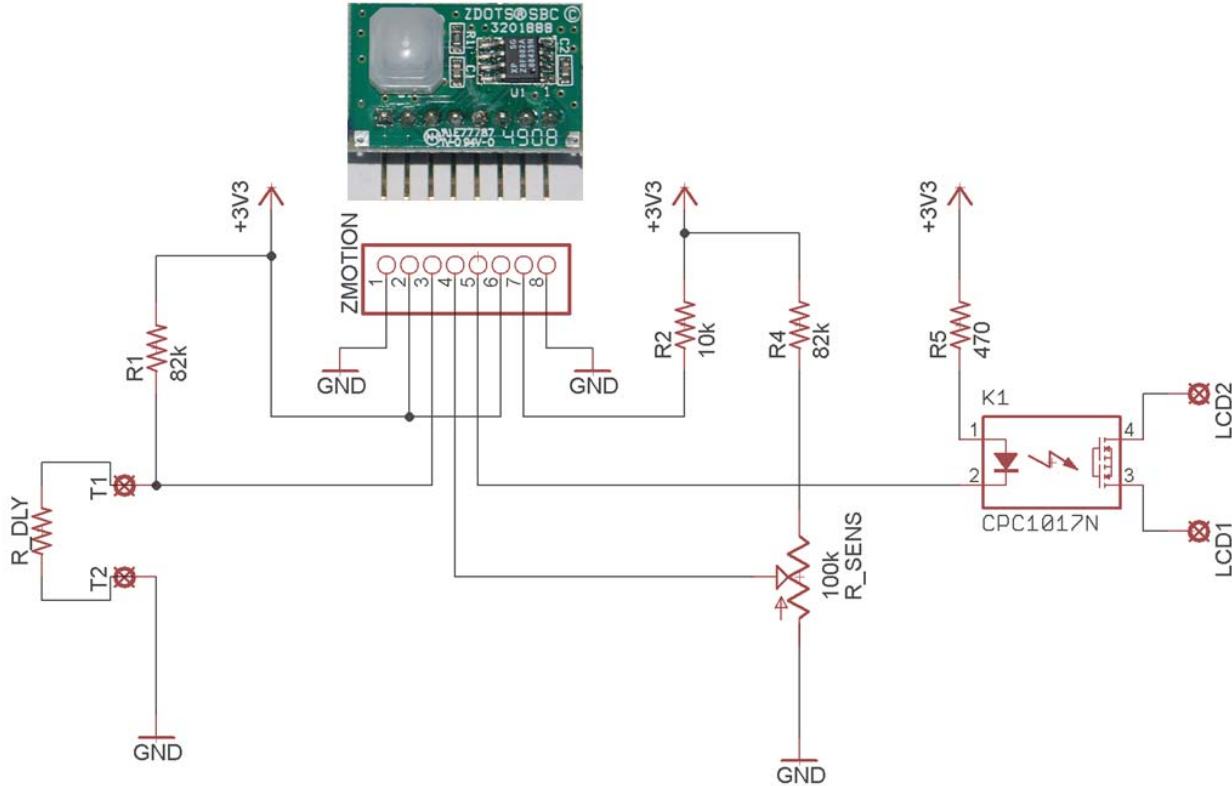

Figure 3: Schematic Diagram

Figure 3 illustrates the connection of ZMOTION™ Detection Module to the solid state relay (K1) and two voltage divider circuits created by R1/R_DLY and R4/R_SENS used to control Delay Time and Sensitivity.

Pin 1 and 8 are Ground (GND) signals and connected internally on the module. Pin 2 is the VDD supply voltage which is set to 3.3V.

Power Control:

The solid state relay controls power to the display on the Digital Picture Frame. Power lines to the LCD (see Figure 4) are connected to LCD1 and LCD2 terminals of solid state relay. When the module detects motion, it will send logic 0 to pin 5 (/MD), activating the solid state relay to the LCD ON. If no motion is detected for the specified Delay Time, the module will send logic 1 to pin 5, deactivating the solid state relay, and turning the LCD OFF.

Power On Time:



Changing the R_DLY resistor value changes the time that the LCD power stays on after motion is detected as listed in Table 2. The voltage created by the R1/R_DLY divider is connected to the DLY input pin on the module (pin 3).

From Figure 3, R_DLY resistor value is determined through the voltage divider formula (R1=82kΩ):

$$R_DLYVoltage = Vdd * \frac{R_DLY\ ResistorValue}{82k + R_DLY\ ResistorValue}$$

$$\text{Thus, } R_DLY\ ResistorValue = \frac{X * 82k}{1 - X}$$

$$\text{Where, } X = \frac{R_DLYVoltage}{Vdd}$$

Table 2 shows standard resistor values calculated for R_DLY, based on the equation above.

Table 2: Delay Time Resistor Values (R1 = 82kΩ)

Delay Time	R_DLY Voltage	R_DLY Standard Resistor Value
2 sec	0 V	0 Ω
5 sec	0.2 V	5.1 kΩ
10 sec	0.4 V	11 kΩ
30 sec	0.6 V	18 kΩ
1 min	0.8 V	24 kΩ
2 min	1.0 V	33.2 kΩ
3 min	1.2 V	43 kΩ
5 min	1.4 V	56 kΩ
10 min	1.6 V	68 kΩ
15 min	1.8 V	91 kΩ

Sensitivity Control:

The R_SENS potentiometer is used to adjust sensitivity. Fine tuning sensitivity to the environment minimizes false triggers. A lower voltage value from R_SENS increases the sensitivity of the ZMOTION™ Detection module to target motion, while higher value decreases sensitivity.

Pin 4 is the SNS input signal on the Module; a high impedance analog input that receives the voltage created by the R4/R_SENS voltage divider to control Sensitivity. A lower input voltage to this pin provides higher sensitivity and higher input voltage provides lower sensitivity.

This pin also selects the Interface Mode during Reset. A voltage on this pin between GND and 2.0V during Reset causes it to enter Hardware Interface Mode. A voltage above 2.4V causes the module to enter Serial Interface Mode. Assuming worst case 5% resistors and a 5% power supply tolerance:

$$SNS_Input_Voltage = 3.3V * 1.05 * \frac{100k * 1.05}{(100K * 1.05) + (82k * 0.95)} = 1.989V$$

Unused Signals

Pin 6 (LG) is the Light Gate input and is not used in this application. It is connected to Vdd.

Pin 7 (/SLP/DBG) is the Sleep mode input. When this pin is Low, the ZMotion™ Detection Module enters a low power Sleep mode. It is not used in this application so it is tied to Vdd. It also used as the Debug input for custom S/W development and device programming.

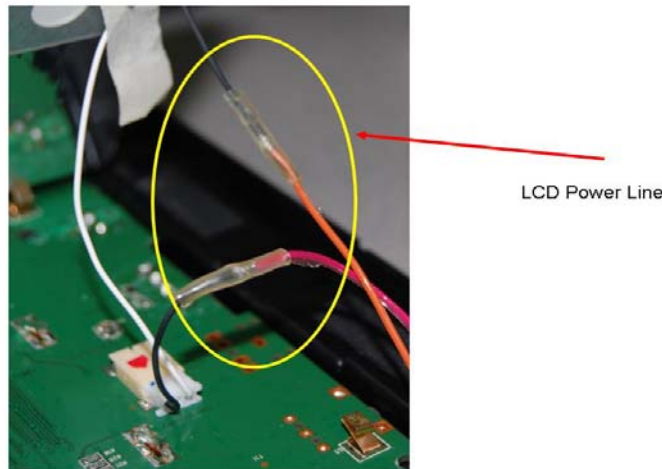

Figure 4: DPF LCD Power Line

As shown in Figure 4, the Digital Picture Frame has two wires that carry power to the LCD screen. The black line is cut and connected to the LCD1 and LCD2 signals from the solid state relay for LCD power ON and OFF control.

Power Savings

Table 3 (below) shows the current consumption of the DPF with power management incorporated. About 90mA savings is achieved with this setup.

Table 3: Current Measured along LCD Power Line

LCD Status	Measured Current in mA
LCD ON	100.82
LCD OFF	0.001
Module Power Consumption	9.0

Summary

Using the ZMOTION™ Detection Module with its flexible control, power management can be incorporated in a number of electrical appliances and commercial lighting related fixtures. With ZMOTION™ technology, appliances can be turned ON or OFF depending on detected human motion.



For this application note, the Digital Picture Frame is able to save power by turning ON only when motion is detected. The LCD lifespan of the DPF is also prolonged as LCD power is turned OFF when not in use.



Warning: DO NOT USE IN LIFE SUPPORT

LIFE SUPPORT POLICY

ZILOG'S PRODUCTS ARE NOT AUTHORIZED FOR USE AS CRITICAL COMPONENTS IN LIFE SUPPORT DEVICES OR SYSTEMS WITHOUT THE EXPRESS PRIOR WRITTEN APPROVAL OF THE PRESIDENT AND GENERAL COUNSEL OF ZILOG CORPORATION.

As used herein

Life support devices or systems are devices which (a) are intended for surgical implant into the body, or (b) support or sustain life and whose failure to perform when properly used in accordance with instructions for use provided in the labeling can be reasonably expected to result in a significant injury to the user. A critical component is any component in a life support device or system whose failure to perform can be reasonably expected to cause the failure of the life support device or system or to affect its safety or effectiveness.

Document Disclaimer

©2010 by Zilog, Inc. All rights reserved. Information in this publication concerning the devices, applications, or technology described is intended to suggest possible uses and may be superseded. ZILOG, INC. DOES NOT ASSUME LIABILITY FOR OR PROVIDE A REPRESENTATION OF ACCURACY OF THE INFORMATION, DEVICES, OR TECHNOLOGY DESCRIBED IN THIS DOCUMENT. ZILOG ALSO DOES NOT ASSUME LIABILITY FOR INTELLECTUAL PROPERTY INFRINGEMENT RELATED IN ANY MANNER TO USE OF INFORMATION, DEVICES, OR TECHNOLOGY DESCRIBED HEREIN OR OTHERWISE. The information contained within this document has been verified according to the general principles of electrical and mechanical engineering.

Zdots, Z8, Z8 Encore!, ZMOTION and Z8 Encore! XP are registered trademarks of Zilog, Inc. All other product or service names are the property of their respective owners.