

Use a Self-Powered Op Amp to Create a Low-Leakage Rectifier An Amplifier that Works at 0.8V is Key

Martin Tomasz
Touchstone Semiconductor, Inc.

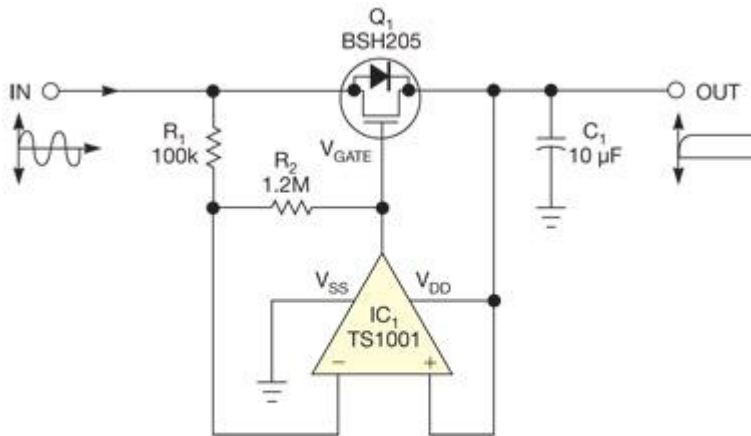

Figure 1 This circuit emulates a rectifier, but it has forward-voltage drop of 40 mV or less. The circuit has less reverse leakage than a Schottky diode.

You can combine a carefully chosen op amp, a low-threshold P-channel MOSFET, and two feedback resistors to make a rectifier circuit with less forward drop than a diode (Figure 1). The rectified output voltage powers the active circuitry, so no additional power supply is necessary. The circuit's quiescent current is lower than most Schottky diodes' reverse-leakage current. This circuit provides active rectification at voltage drops as low as 0.8V. At lower voltages, the MOSFET's body diode takes over as an ordinary diode.

The op-amp circuit turns on the MOSFET as a forward voltage develops between the input and the output voltages, according to the following equation:

$$V_{\text{GATE}} = V_{\text{OUT}} - (R_2/R_1)(V_{\text{IN}} - V_{\text{OUT}}),$$

where V_{GATE} is the MOSFET's gate drive, V_{IN} is the input voltage, and V_{OUT} is the output voltage. You can relate the input and the output voltages to the MOSFET's drain-to-source and gate-to-source voltages, according to the following equations:

$$V_{\text{DS}} = V_{\text{IN}} - V_{\text{OUT}} \text{ and } V_{\text{GS}} = V_{\text{GATE}} - V_{\text{OUT}},$$

where V_{DS} is the drain-to-source voltage and V_{GS} is the gate-to-source voltage. Combine these **equations** to relate the MOSFET's gate drive to a function of the drain-to-source voltage:

$$V_{\text{GS}} = -(R_2/R_1)V_{\text{DS}}.$$

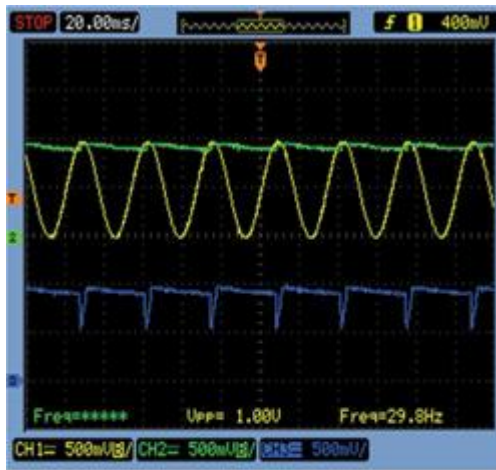

Figure 2 The output of the circuit (green) with a sine-wave input (yellow) shows that the FET's gate voltage (blue) drops out only when the input-to-output differential is less than 40 mV.

If you make R_2 12 times larger in value than R_1 , a 40-mV voltage drop across the MOSFET's drain-to-source voltage is sufficient to turn on the MOSFET at low drain currents (Figure 2). You could choose a higher ratio to further reduce the voltage drop within the limits of the op amp's worst-case input-offset voltage of 6 mV. The op amp is powered from output-reservoir capacitor C_1 . The amplifier has rail-to-rail inputs and outputs and no phase inversion when operating near the rails. The amplifier operates at power-supply voltages as low as 0.8V. You directly connect the op amp's non-inverting input to the V_{DD} rail and the amp's output to the gate of the MOSFET. The circuit consumes slightly more than 1 μ A when actively rectifying a 100-Hz sine wave, less current leakage than that of most Schottky diodes. The BSH205 supports milliamp-level currents at a gate-to-source voltage of 0.8V.

The op amp's bandwidth limits the circuit to lower-frequency signals. At bandwidths higher than 500 Hz, the

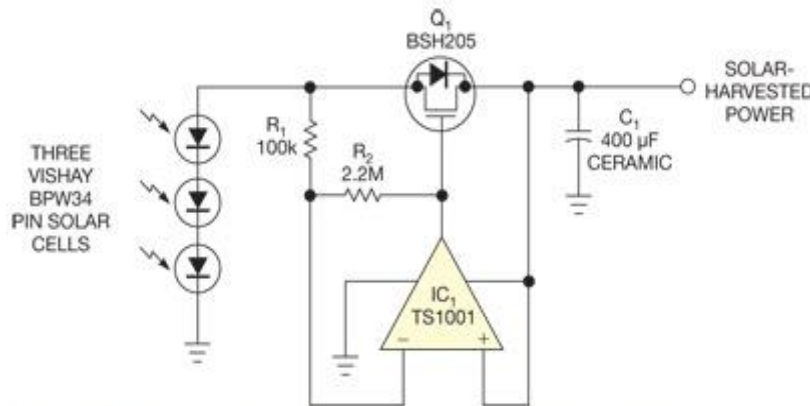

Figure 3 You can use the active-rectifier circuit to charge a capacitor from solar cells. The rectifier has low voltage drop and protects the cells from reverse current when there is no light.

amplifier's gain begins to decline. As the signal frequency increases, the MOSFET remains off, and the body diode of the MOSFET takes over the rectification function. An input with a fast fall time could potentially drag the output with reverse current through the MOSFET. However, for small currents, the MOSFET operates in its

sub-threshold range. The amplifier quickly turns off due to the exponential relationship of the gate-to-source voltage to the drain-to-source current in the sub-threshold range. The limiting factor is the amplifier's slew rate of 1.5V/msec. As long as you don't load the circuit so heavily that you drive the MOSFET into its linear range, reverse currents won't exceed forward currents.

You can use the circuit in a micropower solar-harvesting application (Figure 3). Depending on the light, the BPW34 cells generate 10 to 30 μA at 0.8 to 1.5V. The active-diode circuit rectifies the peak harvested voltage in conditions of rapidly changing light and minimizes reverse leakage to the cells.

For additional information, please follow the links to the corresponding product pages:

- [TS1001 Op Amp](#)

For additional information, contact:
Touchstone Semiconductor Applications
Applications@TouchstoneSemi.com
+1 (408) 383-9363